

APPROVED			
CH.	ABB	DATE	3/29/96
DR.	ABB		
FOR DIRECT FIRED, CLOSED SYSTEM HEATING WITH 3 WAY VALVE			
USED ON PARKER HOT WATER SYSTEMS		PART NAME	
BOILER PIPING SCHEMATIC		A201-INST3.DWG	
PARKER BOILER CO. 5930 BANDINI BLVD. LOS ANGELES, CALIF. 90040			
SCALE		NONE	
SUPERCEDES NO.		3-18-93	
DWG. NO.		A201-INST3	

NOTE:

- 1) System pump should run at all times boiler is energized. When heat is no longer required, electrical power to boiler should be disconnected and pump should run for 5 – 15 minutes before being turned off.,
- 2) When 3 way valve is utilized, a minimum position stop on 3 way valve or an open bypass should be utilized to insure a small flow thru boiler.

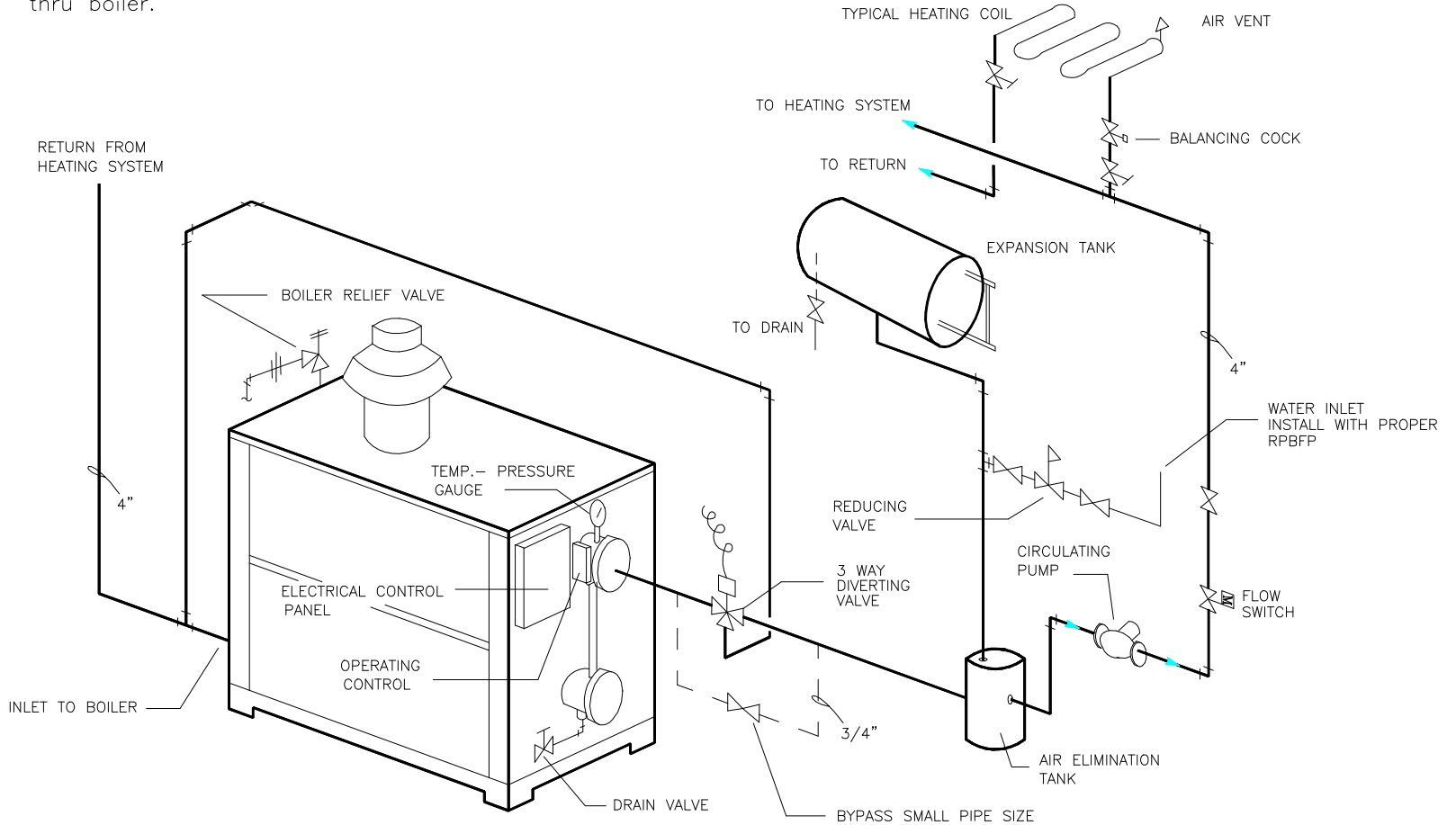

SINGLE BOILER WITH 3 WAY VALVE HOT WATER PIPING SCHEMATIC

TYPICAL FOR EACH