

PARKER BOILER CO. AUTOMATIC COMPOUND FEEDER FOR STEAM BOILERS

The accurate and uniform introduction of the proper ratio of chemicals to the boiler system is a basic requirement for a satisfactory water treatment program.

The **AUTOMATIC COMPOUND FEEDER** has been developed to provide a controlled automatic method for more efficiently and economically adding treatment while the boiler is in operation. This feeder has the advantage of far more positive and uniform treatment control than is possible by the batch or drip feeder method.

ADVANTAGES AND FEATURES

1. Easy and positive method of uniformly adding water treatment to steam boiler(s).
2. Automatic reliable Chem-Feed Metering Pump delivers an adjustable rate and stroke length to meet chemical quantity requirements.
3. Heavy duty industrial quality chemical pump will out last the standard commercial grade units.
4. Rated for 150 PSI so chemical can be injected directly into water feed line.
5. All fittings with hose for connecting to boiler return tank.
6. A complete automatic compound feeder package is available with a 15, 30, 35, or 50 gallon tank, and optional 35 gal. tank with agitator.
7. Saves Labor: The Compound Feeder reduces the amount of time required by the Operator for the addition of water treatment to the boiler system.



SHOWN WITH 15 GALLON FEED TANK

EASY TO INSTALL

Locate the Kit near boiler return system and place hose in tank well or into a tee off the feed line of the return tank. Wire electrical on the compound feed pump. We recommend purchasing the boiler with terminals for chemical feeder. This allows us to size the panel for the correct electrical load while easing your installation.

Electrical furnished standard for pump is 115 Volt 60 Hz 1 Ph, 160 Watts.

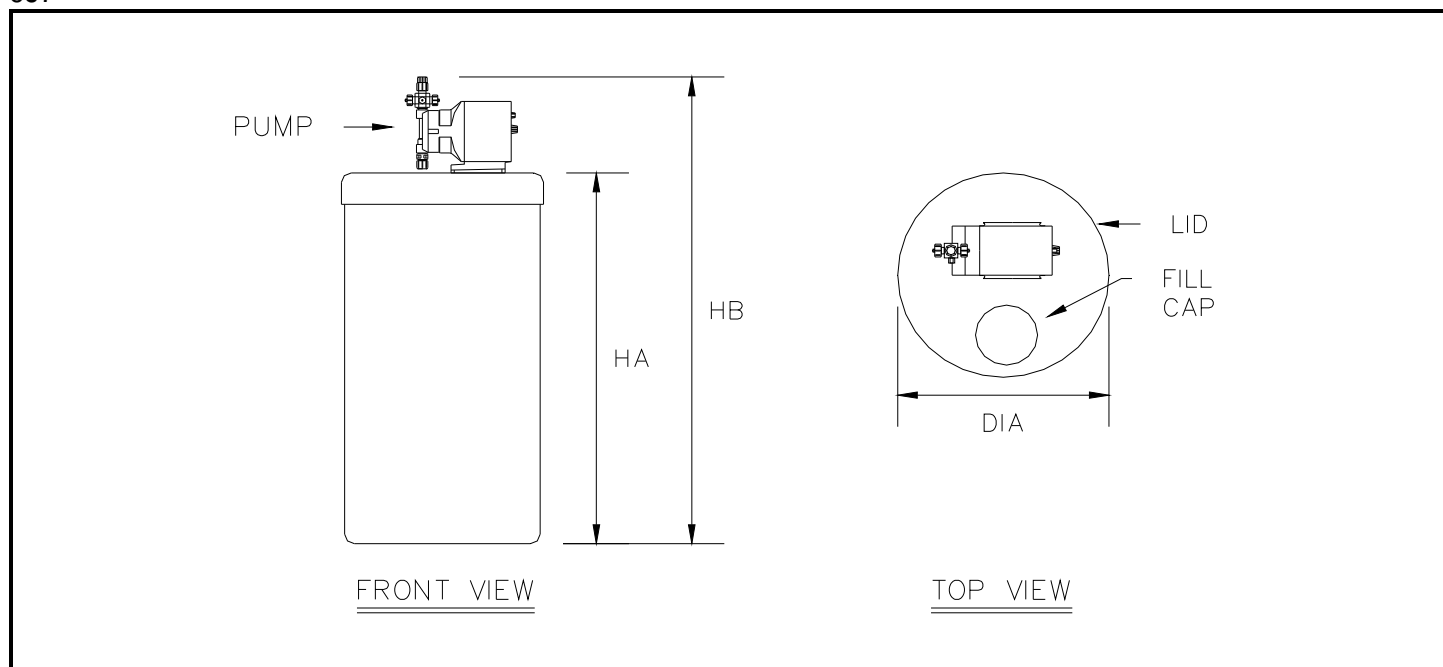

I. SPECIFICATIONS:

NO:	DESCRIPTION:		ST-15	ST30	ST50
HA	HEIGHT OF CONTAINER	IN.	24-1/2	29	33
HB	HEIGHT OVERALL	IN.	33	37-1/2	41-1/2
DIA	DIAMETER	IN.	14-1/2	18-1/2	22-1/2
CAP	CAPACITY OF CONTAINER	GAL.	15	30	50
	SHIPPING WEIGHT – DOMESTIC	LBS.	20	22	28
	SIZE OF SHIPPING CARTON	IN.	15 X 15 X 26	19 X 19 X 31	24 X 24 X 37

II. PARTS:

PART NUMBER:	DESCRIPTION:
CHEMICAL METERING PUMPS	
P121-358TI	LMI CHEMICAL METERING PUMP
27400	LMI 35 GAL TANK WITH (3) OPENINGS - (1) FOR "P" SERIES PUMP, (1) FOR MIXER, (1) FOR CHEMICAL
F-M-TE-H-WRD	WINGERT 1/20 HP 304 SS STAINLESS MIXER AND IMPELLER
TANKS & LIDS (AVAILABLE SEPARATELY)	
1. ST15-TL	Tank and Lid for ST15
2. ST15-L	Lid Only
3. ST30-TL	Tank and Lid for ST30
4. ST30-L	Lid Only
5. ST50-TL	Tank and Lid for ST50
6. ST50-L	Lid Only
PARTS	
1. 38025	Injector Fitting, 1/2T PVDF/PVC
2. 25636-16	Tubing, .250" O.D. Polyethylene
3. 10299	Coupling Nut
4. 38049	3 Function Valve, 1/4T PVC
5. 37750	Molded PVC Head, 0.5 SI
6. 38018	Suction Valve Assembly
7. 10322	Ceramic Weight
8. 38031	Foot Valve Assembly