

INSTALLATION AND MAINTENANCE INSTRUCTIONS BLOWDOWN AND DRAIN CONNECTIONS
PARKER INDUSTRIAL HORIZONTAL DRUM STEAM BOILERS 70 TO 150 H.P.
ATMOSPHERIC GAS FIRED

The proper installation of the Blowdown System and drains are essential to the life and safety of the boiler. The diagram furnished illustrates the recommended installation method and by following these instructions, the equipment will be installed in the best manner for safe and economical operation. It is the experience of the Manufacturer that the life of the equipment will be considerably increased if the Blowdown System is correctly installed and blowdowns made regularly to Manufacturer's Minimum Recommendations.

11. BOILER BLOWDOWN CONNECTIONS: Two Main Blowdown connections are provided directly off of the two bottom mud traps at the rear of the boiler. If more convenient, these may be connected to the front as capped nipples extend out the front side for this purpose and also for convenience of cleaning. Two Header Blowdown Connections are provided on the front and rear center of the boiler above the main blowdown level for purpose of blowing down the tube headers.

11A. MAIN BOILER BLOW-OFF VALVES: Two 2" Main Blow-off Valves are furnished with each boiler and should be installed at the blowdown connection near the boiler in an accessible location for safely and easily blowing down the equipment regularly. The fast-opening blow-off valve is very advantageous on the design of boiler as it provides quick full opening with a quarter of a turn for effectively and thoroughly flushing the boiler. This valve does not require any lubrication, adjustment or maintenance. Always open the valve fully and do not throttle. On complete blowdowns, let the boiler feed pump run 30 to 60 seconds before closing the valve. If the valve does not close freely, do not force, but let the pump run longer to flush any foreign material through the valve to be sure it is clear to close freely.

11B. HEADER BLOW-OFF VALVES: Two 1" Header blow-off Valves, the same type as the main blow-off valves, are furnished with the boiler and should be installed conveniently near the boiler and connected full size into the main blowdown line.

11D. MAIN BLOWDOWN LINE: Connect full 2" size as straight and low as convenient to an approved blowdown tank. The two 2" blowdown lines off of the mud trap and the two 1" header blowdown lines should be piped full size into the 2" main blowdown line as shown on the drawing. All piping, valves, and fittings installed in the blowdown line must be rated for a minimum pressure at least 25% above the working pressure of the boiler. All lines should be safely installed and properly supported. All blowdown lines should be inspected regularly and replaced yearly or immediately on indication of leaks or weakness. Every precaution should be taken to the best interest of safety in preventing personal injury. There should be a means provided for draining the boiler when not under pressure and it is recommended that a 3/4" gravity drain valve be installed at the low point of the main blowdown line as shown and piped to a drain. This valve should be plugged and never be opened during blowdown or while the boiler is under pressure. Use black steel pipe only, no galvanized or copper in these services.

NOTE: On pressures above 100 PSI, one additional **11C. Slow Opening Blow-off Valve (NF)** is required for each boiler and should be installed as shown. Blowdown line piping from the boiler to the second blow-off a valve must be extra heavy steel and should be comparable to Schedule 80.

12D. SAFETY VALVE DRAIN: One **12A. Safety Valve** is standardly furnished with the 70 or 90 H.P. Boiler and two safety valves with boilers 115 H.P. and larger. The drain line from the safety valves should be connected full size to a safe point of discharge or in full compliance with Local Code. It is recommended if connected upward and out of room, a drain line should be provided at low point to keep this line drained. Safety valve line should be properly supported to prevent any strain or damage to the valve body.

18D. DRAIN LINE FROM WATER LEVEL CONTROL: Connect full 1" size to the main blowdown line as shown. The drain valve under the water level control should be flushed daily to keep these lines clean and free from sediment.

30. BLOWDOWN TANK: An adequate size, properly designed approved blowdown tank should be provided for the boiler system, having a capacity of not less than twice the volume of the boiler water so that the boiler can be blown down completely without restriction. See Manufacturer's Blowdown Tank Specification Sheet 115.

31. INTERNAL TANK BAFFLE: All Tanks must have an internal baffle at the blowdown inlet so that the steam distribution will be equalized and directly discharged against the shell of the tank.

32L. BLOWDOWN TANK VENT LINE: Must be run upward to safe location above roof to Local Code Requirements. A full 5" size vent may be required by Local Code; however, a 4" vent is adequate to relieve the pressure on the proper size of Parker Blowdown Tank for pressures up to 150 PSI providing the vent is straight up and not restrictive. Consult the local inspection authority for approval before reducing to this size of vent.

33. BLOWDOWN TANK DRAIN OUTLET: The drain outlet must be connected to an approved open floor sump or safe drain. Run this line the same size as the main blowdown line unless a larger size is required by Local Code. If this water is being discharged into a sewer system, the temperature of the water entering the drainage system should not exceed 140°F. On Parker Blowdown Tanks, the drain outlet is built with a siphon breaker and located so that the tank remains at least 1/2 full of water after each blowdown. The drain outlet is also properly trapped so that water is drained within 6 inches from the bottom of the tank. On multiple boiler installations, a blowdown cooling assembly is recommended.

34. BLOWDOWN TANK CLEANOUT OPENING: A cleanout drain connection of 2" minimum size should be provided at the bottom of the tank. The tank should be inspected and cleaned out every 30 days or as required.

PARKER VERTICAL DRUM STEAM BOILER 70 TO 150 H.P. INSTALLATION DRAWING – REAR VIEW – BLOWDOWN AND DRAIN CONNECTIONS

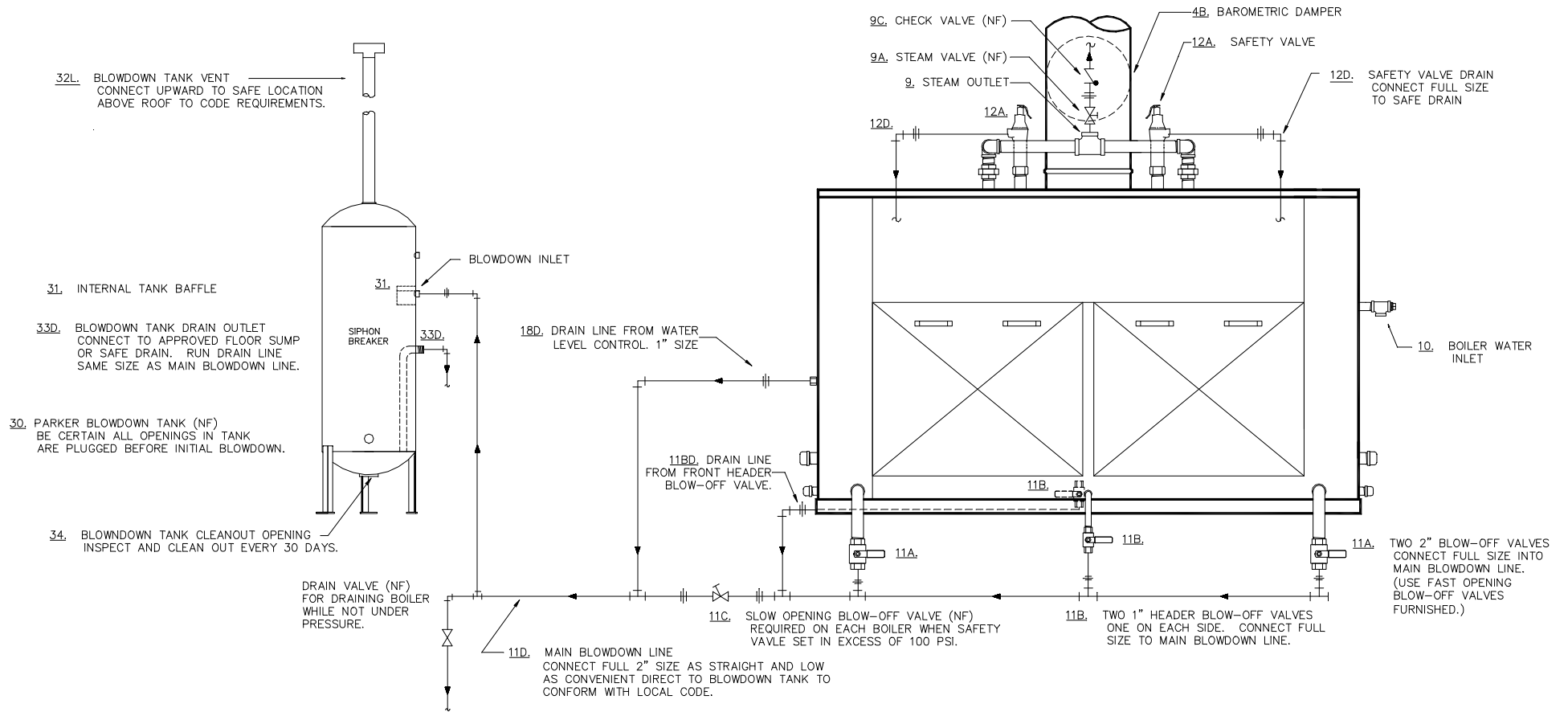

- SLOW OPENING BLOWOFF VALVE
- TEE
- BALL OR GATE VALVE
- CHECK VALVE
- UNION
- (NF) NOT FURNISHED

| | | | |
|--------------------------------------------|---------|----------------------------------------------------------------------|---------------------|
| USED ON 70 TO 150 H.P. STEAM BOILERS | | PART NAME INSTALLATION DRAWING | |
| FOR PARKER STEAM BOILER WITH BLOWDOWN TANK | | | |
| DR. RPC | DATE 8B | PARKER BOILER CO. 5930 BANDINI BLVD. LOS ANGELES, CALIF. 90040 | SCALE CADD DRWG. |
| CH. | | | SUPERCEDES NO. 5/74 |
| APPROVED | | | DWG. NO. 105 INST 1 |

INSTBD105.DWG