

PARKER BOILER CO.
MOTOR STARTING RELAYS

123 MSR
8C

Parker Steam Boilers are furnished with a Pump Motor Starting Relay for each boiler feed pump. These relays are furnished as a means of switching the heavy current load of each boiler feed pump with the lighter duty contacts available in the water level control. They may also be used to energize a water feed valve or remote motor starting relay when the electrical ratings match the boiler electrical service. All three phase feed pumps require a motor starting relay with heaters and all boilers with electrical service over 115 Volts require a control transformer (standard) or separate 115 Volt 1 Phase service for the control circuit. Additional relays may be furnished for other motor starting loads when specified.

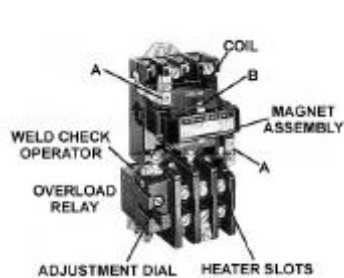

FIG. 1 CR306



FIG. 2 R4243B

WARNING:

1. Only qualified service technicians should attempt to service or repair boiler controls and burner systems.
2. Hazard of electric shock. Line voltage is present in all boiler control circuits. More than one main line disconnect switch may be required to disconnect all power. Always turn off all main line disconnect switches when working on any electrical controls.

OPERATION: Consult Boiler Wiring Diagram.

The motor starting relay is normally mounted in the boiler control panel. If installed in the field it should be mounted vertically in an appropriate enclosure in a cool place. Line service is connected to terminals L1 and L2 for single phase service and L1, L2 and L3 for three phase. The pump motor is connected to terminals T1 and T2 or T1, T2 and T3. When feed pump electrical is over 115 Volts, a control transformer is normally furnished wired to terminals L1 and L2 to operate the boiler control circuit. Whenever the water level control energizes its circuit, indicating that more water is required, the motor starting relay coil is energized from the blue wire. This causes the motor starting relay coil contacts to pull in, starting the boiler feed pump. Single phase motors must have built in overload protection. Three phase motors are protected by the overload relay heaters on the motor starting relay. In the event of an overload, after repairing the cause of overload, the reset button must be manually reset before operation may be resumed. Single phase motors may also use a motor starting relay with overload relay heaters. Owner must provide field installed Motor Branch Circuit Protection in accordance with the National Electric Code. See Page 2 Chart IV.

HONEYWELL R4243B1004 DPST ELECTROMAGNETIC CONTACTOR:

These two pole normally open contactors are furnished as motor starting relays on Parker Boilers for 115 Volt motors with built in overload protection up to 1 horsepower. They feature heavy duty, silver alloy, bridge type double-break contacts. There are no repairable components, therefore, the relay must be replaced if defective.

GENERAL ELECTRIC CR306 MOTOR STARTING RELAY:

The CR306B Nema Size 0 and CR306C Nema Size 1 Motor Starting Relays are furnished on Parker Boilers for motor voltages over 115 Volt. Maximum motor H.P. for each voltage and phasing are labeled on the front of the armature magnet assembly. Overload protection heaters are furnished with new boilers sized for the standard boiler feed pump motor. If the pump electrical is changed or the pump is non-standard, be certain the heaters supplied are properly sized for the pump. See Heater Section Chart II on next page. These relays feature heavy duty vertically-slanted contacts which resist contamination and bounce, easy disassembly of contacts and coil without tools and coil windings protected against dust, oil, mechanical damage and rust.

COIL REPLACEMENT:

1. Remove power from device. Press against coil while pulling up slightly on coil retainers (A-figure 1) and move retainers away from coil.
2. Withdraw magnet assembly, coil, molded cover, and moveable arm from device.
3. Withdraw spring clip (B-Figure 1) and remove armature from movable arm. Remove coil from magnet.
4. Replace coil. Reassemble device by reversing procedure.

CONTACT REPLACEMENT:

1. Perform steps 1 through 3 under Coil Replacement.
2. Remove magnet from molded cover and movable arm. Remove return spring from center of movable arm.
3. Remove molded cover from movable arm. Depress and slide movable contact and spring from movable arm.
4. Remove screws holding stationary contacts in place and remove stationary contacts.
5. Reassemble device by reversing process.

CHECK FOR WELDED CONTACTS IN OVERLOAD RELAY:

With power disconnected, disconnect the control wiring from the relay terminals. Place a bell set or resistance measuring instrument across the relay terminals. Depress and release reset arm to insure relay is reset. In this condition there should be continuity between the terminals. Depress white manual check operator to trip the relay. In the tripped condition the circuit between the terminals should be open indicating the contacts are operating normally. Rewire the terminals and reset the relay for normal operation.

MAINTENANCE:

1. Always remove power from device before performing any maintenance.
2. Keep magnet mating surface free from accumulated dirt or dust.
3. DO NOT OIL OR GREASE the magnet mating surfaces.
4. Contacts are carefully designed for maximum life. They need only to be replaced when nearly all the silver tip is gone and the contact tip support is exposed. DO NOT FILE the contacts. Filing or dressing the contacts only results in lost tip material and reduces life.
5. The ultimate tripping current of the installed relay heater can be adjusted plus or minus 10% by using the adjustment dial, shown in Figure 1.

I. TROUBLE SHOOTING GUIDE:

TROUBLE	POSSIBLE CAUSE	REMEDY
Pump not running – relay coil will not energize. (No voltage at coil)	No electricity to boiler.	Check source of power, fuses, line switch, etc.
	Poor electrical connections.	Disconnect, clean thoroughly. Reconnect and tighten. Replace any broken connections.
	Water level control not energized.	Clean water level control. See water control bulletin. Clean, repair or replace.
Pump not running – relay coil will not energize. (Voltage at coil)	Overload heaters have tripped.	Manually push reset button. Repair cause of overload.
	Relay coil for wrong voltage.	Replace with coil for correct voltage.
	Defective relay coil.	Replace coil or complete relay.
	Mechanical bind.	Check magnet assembly and movable contacts. Manually operate to check.
Pump not running – relay coil energized.	Incorrect electrical supply.	Check pump for proper electrical service required.
	Defective pump wiring.	Check continuity of wiring from motor starter to pump. Tighten all connections.
	Burned out pump motor.	Replace motor.
	No heaters in motor starter.	Install correct size heaters.
	Defective contacts.	Repair or replace.
Pump motor continues to run. Relay coil de-energized.	Burned relay contacts.	Repair or replace contacts or relay.
	Defective armature.	Replace armature (CR306 only).
Heaters repeatedly lock out. (CR306 only)	Motor or equipment.	Check motor load. Repair any mechanical difficulty. Check for stoppage in water feed line.
	Incorrectly sized heaters.	See chart below and actual motor nameplate for correct sized heaters. Replace.
	Excessive ambient temperature.	Adjust temperature compensating dial. Turn counterclockwise to increase setting. Mount relay in cooler area. Repair cause of excessive heat.

II. HEATER SECTION CHART – THREE LEG OVERLOAD PROTECTION (3 HEATERS) – BURKS PUMPS AND 60 HZ SERVICE:

MOTOR SIZE	VOLTAGE				MOTOR SIZE	VOLTAGE	
	230V 3PH	460V 3PH	115V 1PH	230V 1PH		230V 3PH	460V 3PH
1/3 H.P.	CR123 C2.20A	CR123 C1.09A	CR123 C7.78A	CR123 C3.79A	2 H.P.	CR123 C6.30A	CR123 C3.26A
1/2 H.P.	CR123 C2.68A	CR123 C1.31A	CR123 C10.4B	CR123 C4.66A	3 H.P.	CR123 C8.67A	CR123 C4.19A
3/4 H.P.	CR123 C3.56A	CR123 C1.96A	CR123 C13.7B	CR123 C6.30A	5 H.P.	CR123 C13.7B	CR123 C6.30A
1 H.P.	CR123 C3.79A	CR123 C2.20A	CR123 C15.1B	CR123 C7.78A	7-1/2 H.P.	CR123 C19.3B	CR123 C10.4B
1-1/2 H.P.	CR123 C5.92A	CR123 C3.01A	CR123 C21.4B	CR123 C11.3B	10 H.P.	CR123 C27.3B	CR123 C13.7B

III. STANDARD SIZE HEATERS FURNISHED WITH STEAM BOILERS. (SET OF THREE HEATERS)

If the pump or return system is not furnished with the boiler, check to be certain that these heaters supplied are properly sized.

BOILER SIZE	100 PSI		125	
	HEATER MODEL	PUMP MOTOR – 230/60/3	HEATER MODEL	PUMP MOTOR – 230/60/3
20 H.P.	CR123 C3.56A	3/4 H.P.	CR123 C3.56A	3/4 H.P.
25 H.P.	CR123 C3.56A	3/4 H.P.	CR123 C3.56A	3/4 H.P.
30 H.P.	CR123 C3.56A	3/4 H.P.	CR123 C6.30A	2 H.P.
40 H.P.	CR123 C5.92A	1-1/2 H.P.	CR123 C6.30A	2 H.P.
50 H.P.	CR123 C5.92A	1-1/2 H.P.	CR123 C6.30A	2 H.P.
70 H.P.	(2) CR123 C5.92A	(2) 1-1/2 H.P.	(2) CR123 C6.30A	(2) 2 H.P.
90 H.P.	(2) CR123 C8.67A	(2) 3 H.P.	(2) CR123 C13.7B	(2) 5 H.P.
115 H.P.	(2) CR123 C13.7B	(2) 5 H.P.	(2) CR123 C13.7B	(2) 5 H.P.
150 H.P.	(2) CR123 C13.7B	(2) 5 H.P.	(2) CR123 C13.7B	(2) 5 H.P.

IV. OVERLOAD HEATER SELECTION: - HEATER SELECTION TABLES:

For continuous rated motors with a service factor of 1.15 to 1.25, select the heater with maximum amps equal to or immediately greater than the motor full load current (provides a maximum of 125% protection). For continuous rated motors with no service factor, multiply the full load current of the motor by 0.90 and use this value to select the heater. To protect the heater during short circuit, provide motor branch circuit protection in accordance with the N.E. code, but not to exceed the maximum fuse ratings shown opposite each heater. Tables are for Type 1 enclosed.

NEMA sizes 00, 0, and 1 – for three phase, 3-pole starters, three leg overload protection (3 heaters):

MAXIMUM MOTOR AMPS	HEATER NUMBER CR123	MAXIMUM FUSE RATING	MAXIMUM MOTOR AMPS	HEATER NUMBER CR123	MAXIMUM FUSE RATING
.44	C0.54A	3	4.67	C4.66A	15
.48	C0.60A	3	5.11	C5.26A	20
.54	C0.66A	3	5.67	C5.92A	20
.59	C0.71A	3	6.11	C6.30A	20
.66	C0.78A	3	6.89	C6.95A	25
.78	C0.87A	3	7.59	C7.78A	25
.89	C0.97A	3	8.39	C8.67A	30
.95	C1.09A	3	9.19	C9.55A	30
1.02	C1.18A	3	9.84	C10.4B	30
1.17	C1.31A	3	10.8	C11.3B	35
1.31	C1.48A	3	11.3	C12.5B	35
1.42	C1.63A	3	12.5	C13.7B	40
1.55	C1.84A	6	14.5	C15.1B	45
1.66	C1.96A	6	16.5	C16.3B	50
1.82	C2.20A	6	17.9	C18.0B	60
2.04	C2.39A	6	19.6	C19.3B	60
2.28	C2.68A	6	20.6	C21.4B	70
2.61	C3.01A	10	23.1	C22.8B	80
2.97	C3.26A	10	24.7	C25.0B	80
3.37	C3.56A	10	25.9	C27.3B	80
3.68	C3.79A	10	27.0	C30.3B	90
4.31	C4.19A	15			

When reassembling note that the magnet and moveable arm assembly (Items 5 through 10) will fit **only one way**. The magnet, Item 8, and moveable arm, Item 7, will fit either way but will be quieter if reassembled the same way they were taken apart.

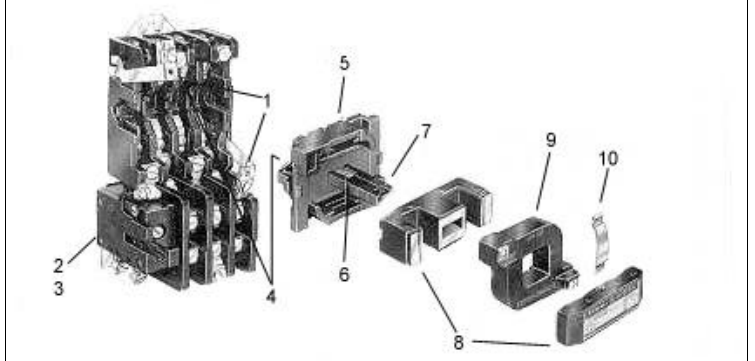

REF NO.	PART NUMBER	PRINCIPAL RENEWAL PARTS
	CR123C---	GE heater for CR306 (specify size)
4	546A300G2	Contact kit for CR306B Size 0
OR	OR	OR
4	546A301G2	Contact kit for CR306C Size 1
8	546A301G054	Armature and frame (magnet)
9	15021G2	Operating coil for CR306 115V
10	546A588P001	Spring retainer for armature